

# AT-9542PT

SLIP-ON MUFFLER, PERFORMANCE  
2013-UP POLARIS SCRAMBLER 850

# MBRP®

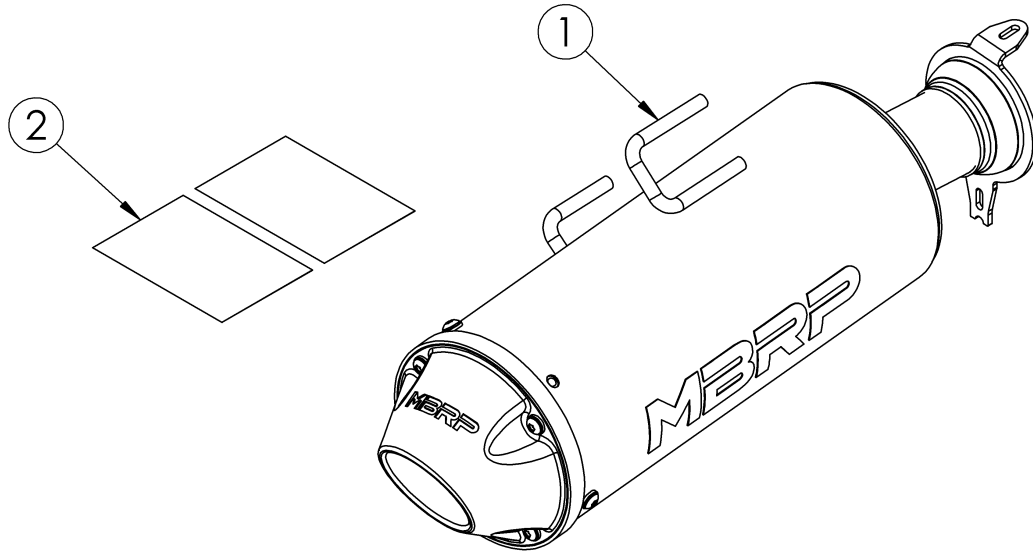

ITEM NO.	DESCRIPTION	QTY
1	MUFFLER ASSEMBLY	1
2	FOIL TAPE	2

Refer to this LOT NUMBER when contacting customer service: \_\_\_\_\_

## PLEASE READ BEFORE STARTING INSTALLATION

While MBRP has made every effort to ensure that all components of this system are of superior quality and properly packaged, it is the installer's responsibility to ensure the following before removal of the factory exhaust:

- that ALL components shown above are present.
- that ALL mating components fit together.
- that there are no damaged components.
- that the system you have purchased is appropriate for your vehicle year, model and configuration.
- that the system will not interfere with any modifications previously installed or planned.
- that you have read and understand these instructions.

If you have any questions or are uncertain about any aspect of the installation of this system to your vehicle please contact your dealer before commencing installation.

# MBRP



Figure 1



Figure 2



Figure 3



Figure 4

## Removal of Stock Exhaust:

1. Remove the two (2) springs securing the muffler to the front pipe. They will be reused.
2. Apply a silicone spray to the front side of the muffler hangers. Next, slide the muffler back to free the hangers from the rubber mounts, and remove the muffler.

## Installation of MBRP Exhaust:

1. Ensure that the stock gasket is in place on the front pipe. **Refer to Figure 1.**
2. Apply the **Foil Tape** to the area of the plastic panel at the rear of the bike, closest to where the muffler will sit. **Refer to Figure 2.**
3. Slide the **Muffler Assembly** hangers into the two (2) rubber mounts and place the inlet onto the stock gasket. **Refer to Figure 3.**
4. Install the two (2) springs onto the muffler inlet. **Refer to Figure 3.**

**It is recommended that the muffler screws (tip and endcap) be retightened after the first ride and checked periodically thereafter, tightening if necessary.**



**Congratulations!** You are ready to begin experiencing the improved performance and driving excitement of your **MBRP** ATV Exhaust upgrade. We know you will enjoy your purchase.



**Figure 1**



**Figure 2**



**Figure 3**



**Figure 4**

## Spark Arrestor Maintenance

In order to maintain optimal performance, the spark arrestor screen should be cleaned after the first 3 hours of use. Afterwards, clean every 30-35 hours of use.

## Clean-out Instructions:

Make sure the vehicle is cool before completing the clean-out procedure.

1. Using a 4mm hex key, remove the 4 screws securing the outlet cap or tip. **(Figure 1)**
2. Remove the outlet cap to expose the spark arrestor screen insert. **(Figure 2)**
3. Remove the screen insert. **(Figure 3)**
4. Using a wire brush, thoroughly brush the screen to remove residue. **(Figure 4)**
5. Replace the screen and cap.
6. Tighten the screws to 60 in-lbs (6.8 Nm).