

# S5273

2024-UP FORD RANGER, 2.3L ECOBOOST,  
CAT-BACK, 3" TURN-DOWN,  
(EXCLUDES 2WD MODELS)

# MBRP®

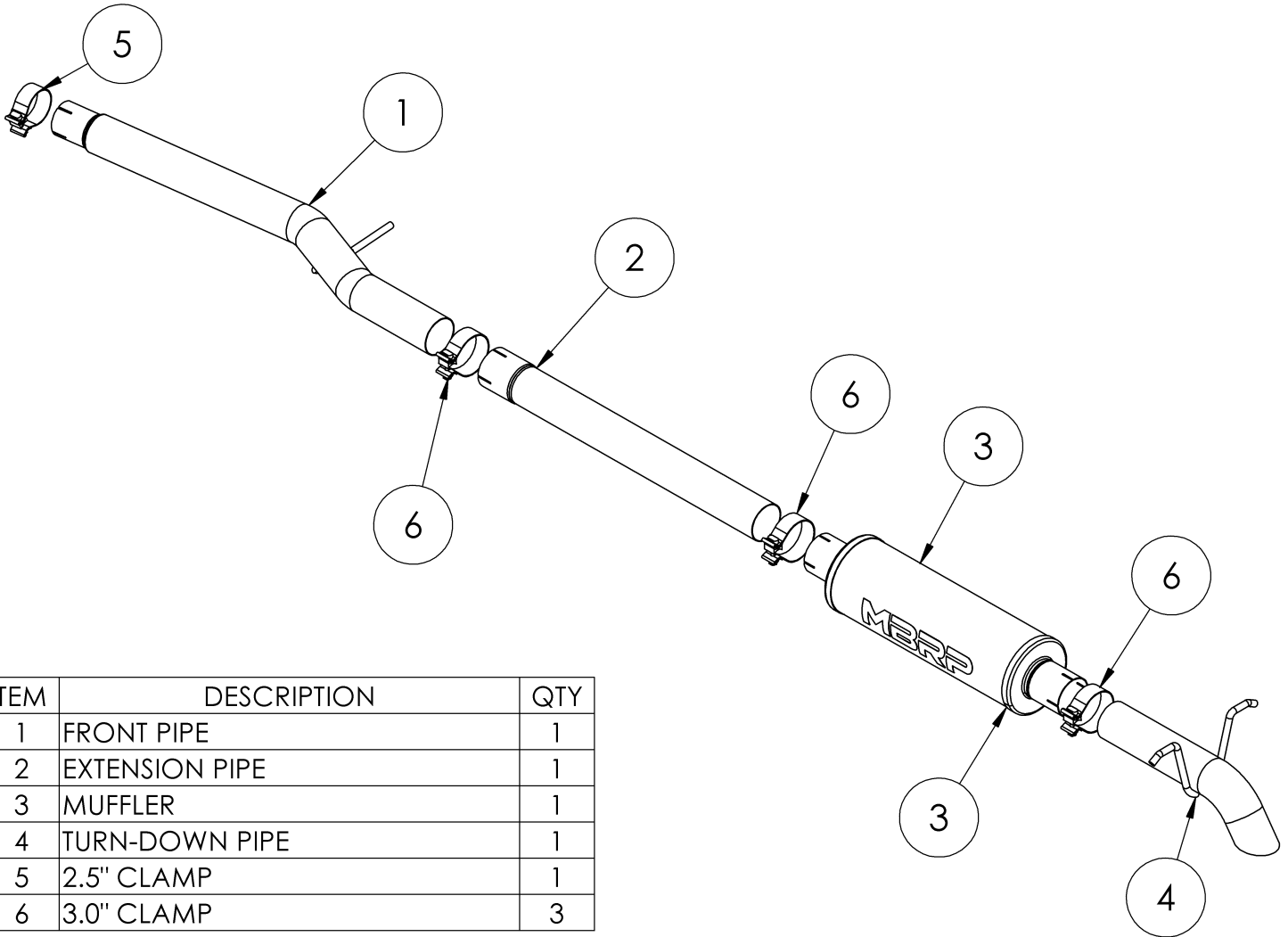

ITEM	DESCRIPTION	QTY
1	FRONT PIPE	1
2	EXTENSION PIPE	1
3	MUFFLER	1
4	TURN-DOWN PIPE	1
5	2.5" CLAMP	1
6	3.0" CLAMP	3

Refer to this LOT NUMBER when contacting customer service: \_\_\_\_\_

## PLEASE READ BEFORE STARTING INSTALLATION

While MBRP has made every effort to ensure that all components of this system are of superior quality and properly packaged, it is the installer's responsibility to ensure the following before removal of the factory exhaust:

- that ALL components shown above are present.
- that ALL mating components fit together.
- that there are no damaged components.
- that the system you have purchased is appropriate for your vehicle year, model and configuration.
- that the system will not interfere with any modifications previously installed or planned.
- that you have read and understand these instructions.

If you have any questions or are uncertain about any aspect of the installation of this system to your vehicle please contact your dealer before commencing installation.

# MBRP

## Removal of Stock System



Figure 1

1. Apply penetrating lubricant liberally to all exhaust fasteners, hangers, and rubber insulators.

2. Remove the front pipe and tail pipe hangers from the vehicle.  
Refer to Figure 1 & 2.

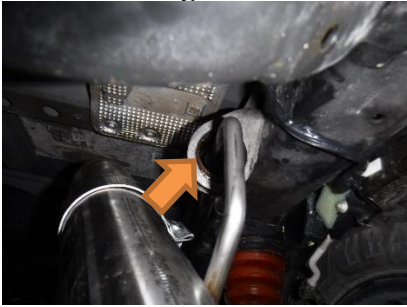

Figure 2

3. Remove the remaining hangers from the rubber insulators and loosen the factory clamps. Remove the exhaust from the vehicle.

## Installation of MBRP Performance Exhaust

1. Install the front factory hanger insulator onto the **Front Pipe** hanger.

2. Using the **2.5" Clamp**, loosely install the **Front Pipe** onto the factory down pipe. Re-install the factory hanger insulator onto the frame.  
Refer to Figure 3 & 4.



Figure 3

3. Using a **3.0" Band Clamp**, loosely install the **Extension Pipe** onto the **Front Pipe**.

4. Using a **3.0" Band Clamp**, loosely install the **Muffler** onto the **Extension Pipe**.  
Refer to Figure 5.



Figure 4

5. Using a **3.0" Band Clamp**, loosely install the **Turn-Down Pipe** into the **Muffler** and factory insulators.  
Refer to Figure 6.



Figure 5

# MBRP



**Figure 6**

6. Carefully align the system. Align the edge of each band clamp with the edge of the joint it is connecting. Tighten all hardware and clamps, starting at the front and working rearward to secure the system. Check along the full length of the exhaust system to ensure there is adequate clearance for fuel lines, vent lines, brake lines, frame, bodywork, suspension and any wiring, etc. If there is any interference detected, relocate or adjust to provide adequate clearance. Ensure all clamp connections are secure and components are unable to rotate or slide. Band clamps (excluding tip hardware) require approximately 45 lb-ft (60 N-m) of torque. Verify clearances, system security and band clamp torque after 30-60 miles (50-100 km) of driving.



**Congratulations!** You are ready to begin experiencing the improved power, sound and driving experience of your **MBRP** Performance Exhaust. We know you will enjoy your purchase!