

S5301

2022-UP TOYOTA TUNDRA, 3.4L,
CAT-BACK, 3.0" SINGLE SIDE

MBRP®

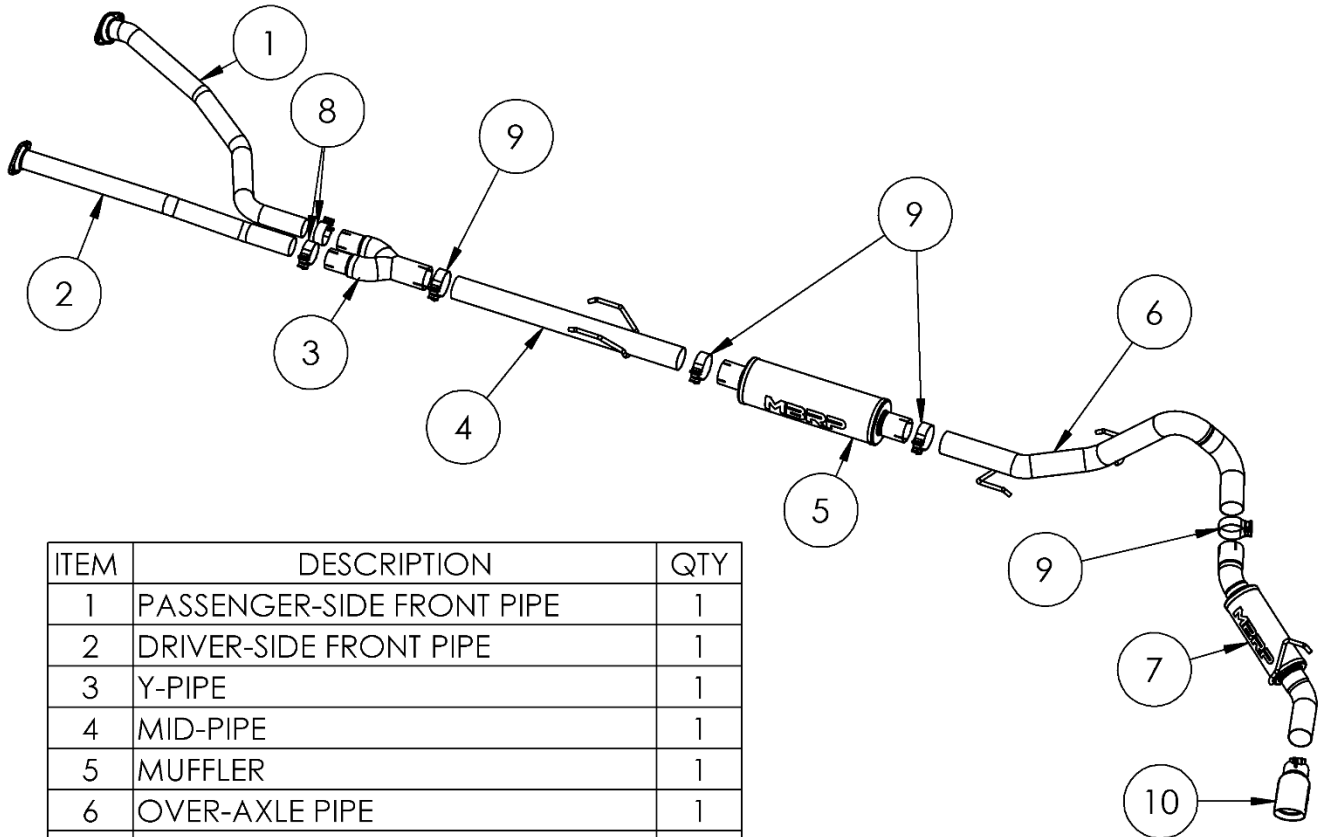

ITEM	DESCRIPTION	QTY
1	PASSENGER-SIDE FRONT PIPE	1
2	DRIVER-SIDE FRONT PIPE	1
3	Y-PIPE	1
4	MID-PIPE	1
5	MUFFLER	1
6	OVER-AXLE PIPE	1
7	TAIL PIPE	1
8	2.5" CLAMP	2
9	3.0" CLAMP	4
10	TIP	1

PLEASE READ BEFORE STARTING INSTALLATION

While MBRP has made every effort to ensure that all components of this system are of superior quality and properly packaged, it is the installer's responsibility to ensure the following before removal of the factory exhaust:

- that ALL components shown above are present.
- that ALL mating components fit together.
- that there are no damaged components.
- that the system you have purchased is appropriate for your vehicle year, model and configuration.
- that the system will not interfere with any modifications previously installed or planned.
- that you have read and understand these instructions.

If you have any questions or are uncertain about any aspect of the installation of this system to your vehicle please contact your dealer before commencing installation.

MBRP

Removal of Stock System



Figure 1

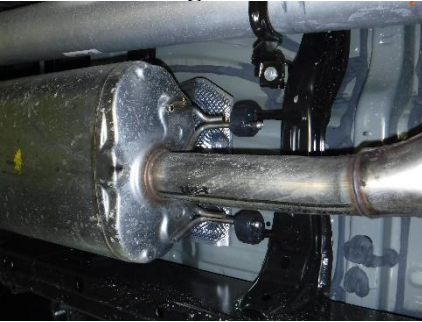

Figure 2

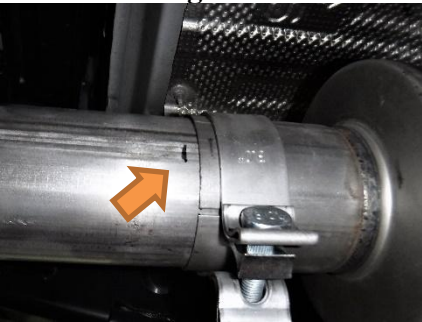

Figure 3



Figure 4



Figure 5

1. Apply penetrating lubricant liberally to all exhaust fasteners, hangers, and rubber insulators.
2. Lower the spare tire and remove the two nuts securing the tail pipe to the muffler.
3. Remove the rear tail pipe insulator from the vehicle and work the tail pipe out of the remaining insulator and out over the rear axle. The suspension will have to be in droop to remove the tail pipe in one piece.
Refer to Figure 1.
4. Remove the spring mounting hardware directly behind the catalytic converters on both sides. Retain the mounting hardware for the installation.
5. Remove the rear muffler insulator from the vehicle and remove the muffler from the remaining two rubber insulators.
Refer to Figure 2.

Installation of MBRP Performance Exhaust

1. To help ensure system alignment, mark a line 3" from the end of each pipe where it would go into an expansion. The edge of the expansion should be approximately $\frac{1}{4}$ " from these lines when the joint is properly assembled.
Refer to Figure 3.
2. Install the **Passenger-Side Front Pipe**, and **Driver-Side Front Pipe** onto their respective factory catalytic converter flanges using the previously removed spring mounting hardware. Ensure the shoulder of the bolt passes through the flange. Passenger-side shown.
Refer to Figure 4.
3. Install the **Y-Pipe** onto both **Front Pipes** using the two **2.5" Clamps**. Place a **3.0" Clamp** onto the **Y-Pipe** outlet. Do not fully tighten any clamps until the final step.
Refer to Figure 5.

MBRP

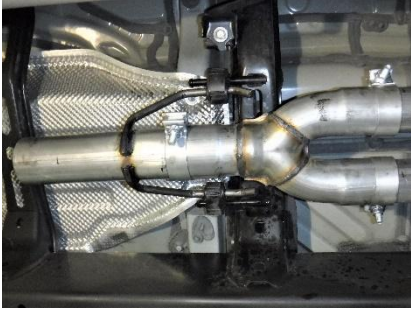

Figure 7



Figure 8

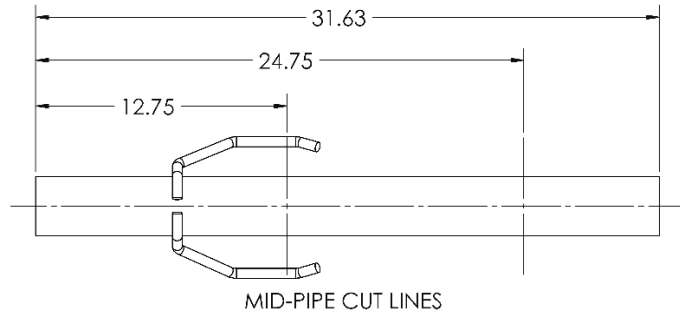

Figure 9



Figure 10

4. Determine the overall length of the **Mid-Pipe**. Mark a line and cut if required. Take care to not damage the hangers. Refer to **Figure 6 (Below)**.



WHEELBASE	MID-PIPE LENGTH
146" CrewMax 5.5' Box / Double Cab 6.5' Box	12.75"
158" CrewMax 6.5' Box	24.75"
164.5" Double Cab 8.1' Box	31.625" (NO CUT)

Figure 6.

5. Install the **Mid-Pipe** into the factory rubber insulators and into the **Y-Pipe**. Refer to **Figure 7**.

6. Place a **3.0" Clamp** on each end of the **Muffler** and slide the **Muffler** onto the **Mid-Pipe**. Refer to **Figure 8**.

7. Install the **Over-Axle Pipe** into the factory insulator over the axle and into the **Muffler**. Reinstall the factory rear muffler insulator onto the vehicle and **Over-Axle Pipe** hanger. Refer to **Figure 9**.

8. Place a **3" Clamp** onto the **Tail Pipe**. Install the **Tail Pipe** onto the **Over-Axle Pipe** and reinstall the rear tail pipe insulator. Refer to **Figure 10**.

9. Install the **Tip** and adjust to your liking. Refer to **Figures 11 and 12**.

10. Raise the spare tire back into position.

MBRP



Figure 11

11. Carefully align the system and tip. Align the edge of each band clamp with the edge of the joint it is connecting. Tighten all hardware and clamps, starting at the front and working rearward to secure the system. Check along the full length of the exhaust system to ensure there is adequate clearance for fuel lines, vent lines, brake lines, frame, bodywork, suspension and any wiring, etc. If there is any interference detected, relocate or adjust to provide adequate clearance. Ensure all clamp connections are secure and components are unable to rotate or slide. Band clamps require approximately 45 lb-ft (60 N-m) of torque. Verify clearances, system security and band clamp torque after 30-60 miles (50-100 km) of driving.



Figure 12



Congratulations! You are ready to begin experiencing the improved power, sound and driving experience of your **MBRP** Performance Exhaust. We know you will enjoy your purchase!